

Description	Part Number	Rev
GUZZI OIL MANIFOLD	-	A

- NOTES:
- MATERIAL: ALUMINUM ALLOY PER: 6061 T6
WEIGHT: 0.117 Lbf
VOLUME: 41612.334 in³
 - FINISH: -
PER: -
 - GEOMETRY NOT DIMENSIONED ON THIS DRAWING IS CONTROLLED BY BASIC DIMENSIONS CONTAINED IN THE APPROPRIATE CAD MODEL STORED WITH THIS DRAWING. UNLESS OTHERWISE SPECIFIED, ALL GEOMETRY SHALL BE WITHIN:

⌒	.050	A	B	C
---	------	---	---	---

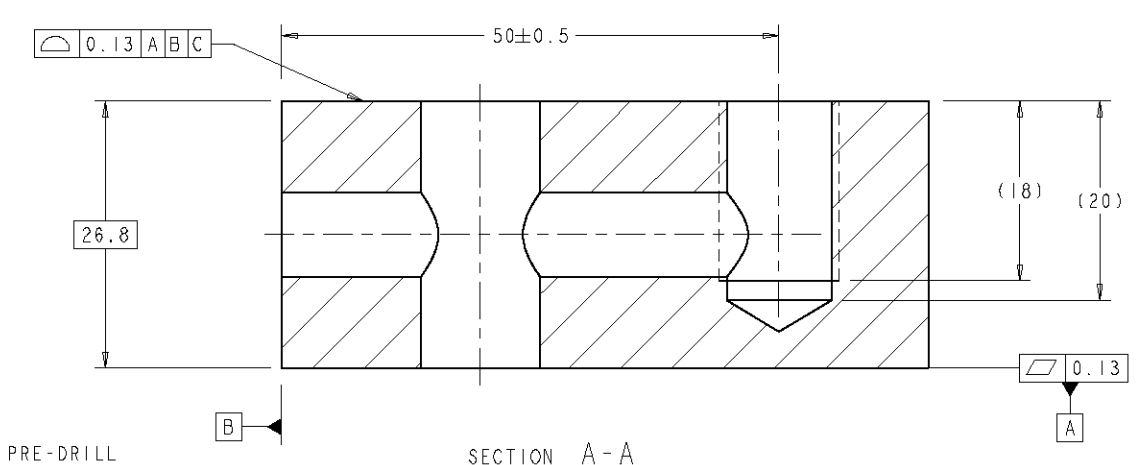
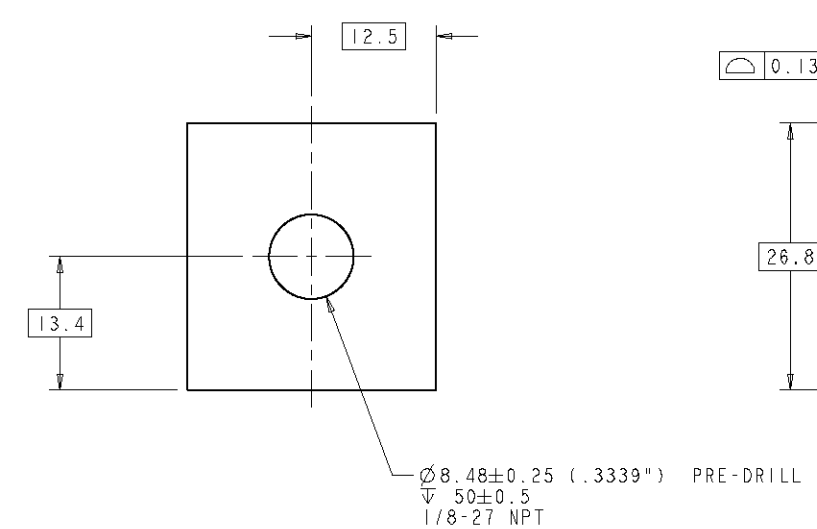
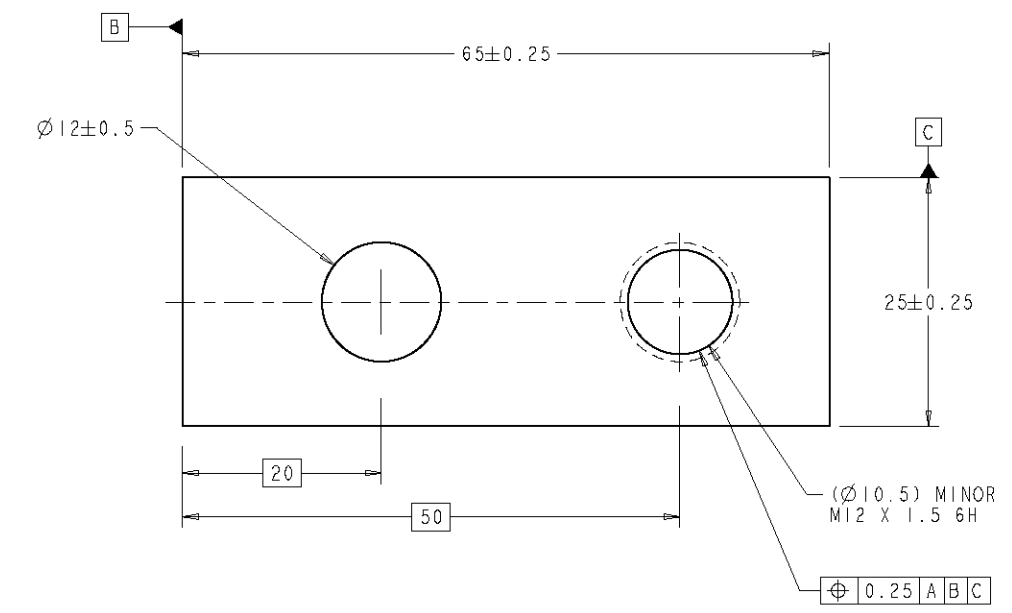

Steelcase Inc.
 © 2009 Grand Rapids, MI USA 49501

Notice: This drawing contains information that Steelcase Inc. considers proprietary and confidential. No portion of this drawing may be reproduced or copied without prior written permission of Steelcase Inc.

Drafted in accordance with Steelcase engineering document ENG 2300.

3RD ANGLE PROJECTION

Drawn By	Date	ER Number
E. PETERSON	01APR09	
Dimensions are in mm (SI)	Sheet	Rev
D	1 of 1	A

PRO/ENGINEER

NAME:EPETERS1 OBJECT:MANIFOLD DATE:01-Apr-09 18:04:20