



Le Mans
1000

ADDITION TO THE OWNER'S MANUAL
FOR USA - MODEL 1986

These motorcycles conform with U. S. Environment Protection Agency Emissions Regulations applicable to motorcycles for **1986** model year. However, to maintain the vehicle within this compliance it is necessary to follow all the servicing and lubrication instructions indicated.

It is also very important for all the specified running in instructions to be strictly observed.

All maintenance and lubrication jobs should al-

ways be carried out by our dealers who have qualified personnel and the necessary facilities, also original MOTO GUZZI spares.

ON REAR FENDER, UNDER SEAT

VEHICLE EMISSION CONTROL INFORMATION

SEIMM - Co. ITALY

Trade Mark: MOTO GUZZI

Engine Size: **948,8 c.c.**

Engine Family: «VV»

Engine Tune-up specification: Adjustments performed in neutral
Breaker point gap: 0.37 - 0.43 mm.

Ignition timing: 8 degree B.T.D.C.

Idle speed: **950 ± 50 rpm** (Warm engine, CO 2,5+3%)

- Adjustment by stop screw

- Adjustment CO % by pilot screw

Recommended Fuel: Leaded (97 NO-RM)

Engine oil: SE in API classification and viscosity 10 W 50 SAE

**THIS VEHICLE CONFORMS TO U. S. EPA REGULATIONS
APPLICABLE TO 1986 MODEL YEAR NEW MOTORCYCLES**

MAINTENANCE RECORD

MODEL		FRAME SERIAL NUMBER	
Recommended mileage	Workshop name	Carried out (clock reading)	Date
900 mi.			
1800 mi.			
3700 mi.			
5600 mi.			
7500 mi.			

Recommended mileage	Workshop name	Carried out (clock reading)	Date
9400 mi.			
11300 mi.			
13200 mi.			
15100 mi.			
17000 mi.			
18900 mi.			

Detailed receipts verifying the performance of required maintenance should be retained. These receipts should be transferred with the motorcycle to the new owner if the motorcycle is sold.

All servicing and maintenance procedures specified in the owner's manual still apply.

However, the instructions on carburation and idling speed adjustment are changed as follows:

CARBURATION ADJUSTMENT

Warm the engine up to its normal riding temperature by running the machine on the road for a few minutes at moderate cruising speed.

Temperatures to be reached: engine oil about 90 °C (195 °F) - cylinder head (under spark plug gasket): about 140 °C (285 °F).

With the machine in the neutral position, act on screws «D» to adjust throttle slide opening of each carburettor using a two-mercury column vacuummeter connected to the hole on the intake pipes, after removing plug «P».

Idling speed should be adjusted to **900 - 1000 rpm**, checking it with an accurate rev-counter.

Operate on screws «C» until both exhaust pipes emit the same amount of CO: **2,5 ± 3%**.

Note - If by screwing in or out adjusters «C», the idling speed adjustment should change, it will be necessary to restore it to **900 - 1000 rpm** acting again on screws «D», checking always throttle

slides opening with a vacuummeter. If necessary, adjust again the CO emission.

After this, slowly and gradually turn the twist grip control to synchronize valves opening, checking on the vacuummeter dial if in each grip position

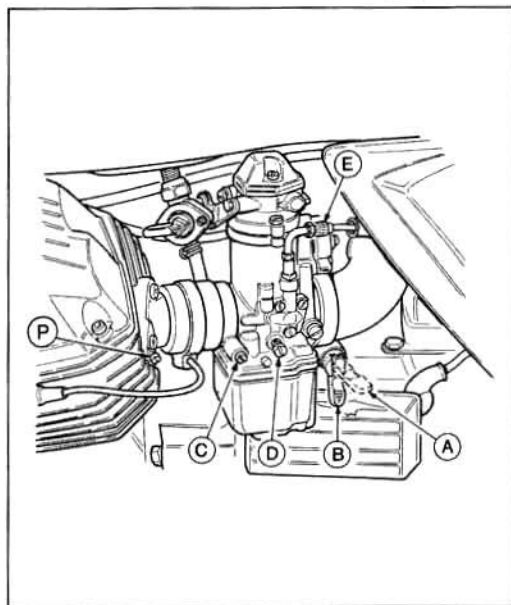

the slides have the same opening. If not, undo locknuts and act on adjusters.

Note - Before proceeding with the carburation adjustment, it is necessary to make sure that the starting and riding position («A» and «B» respectively) of the easy start device are accurately set, adjusting any slight offset through the cable adjusters.

With the easy start lever in position «B», there should be about 3 mm (.11") play between the cable terminal and adjusters «E».

If not, adjust through these, after loosening the locknuts.

Caution - Do not carry out any carburation adjustments before all others have been made (ignition, rocker clearance, etc.).

Standard carburettor setting

N. 2 carburettors «Dell'Orto» type PHM 40 N

Choke	Ø 40 mm
Throttle valve	50/3 (11864)
Atomiser	260 AB1
Main jet	150
Idling jet	62
Starter jet	60
Needle	K 33 (3rd notch)
Floater	10 gr

SEIMM MOTO GUZZI S. p. A. Mandello del Lario

Registro Società Lecco N. 2220

