

# PERTRONIX<sup>INC</sup>

440 E. Arrow Hwy.  
San Dimas, CA 91773  
800-827-3758  
www.pertronix.com



## INSTRUCTION SHEET



Before installing, please read the following important information...

1. The *Ignitor* is designed to be used in **12-volt negative ground** systems.
2. The *Ignitor* is compatible only with a "**points style**" coil. **Six & eight** cylinder engines require a **minimum of 1.5 ohms of resistance**. **Four cylinder** engines require a **minimum of 3.0 ohms of resistance**.
3. If your ignition system presently **has a ballast resistor, do not remove it**. (See Figure 3).
4. **Caution: never** use a "**HEI**" type coil with the *Ignitor*. This type of coil will damage the module, cause it to fail, and void the warranty.
5. The **red** wire from the *Ignitor* must be connected to the **positive (+)** side of the coil, or a 12 volt switching power source. The black wire must be connected to the negative (-) side of the coil. (See Figure 2 & 3).
6. Some magnet sleeves may have green tape, **DO NOT REMOVE IT**.

### **PRIOR TO INSTALLATION TURN THE IGNITION SWITCH OFF OR DISCONNECT THE BATTERY.**

1. Remove the distributor cap and rotor. Do not disconnect spark plug wires from cap. Examine cap and rotor for wear or damage. Replace as needed.
2. Disconnect the points wire from the negative (-) side of the coil.
3. Remove the points, condenser, and grommet.

4. The *Ignitor* does not require any modification to distributor. Therefore the points, condenser, and hardware can be used as backup.
5. Clean any oil or dirt from the breaker plate and cam.
6. Insert the *Ignitor* black and red wires through the distributor housing verifying the grommet is seated properly.
7. Install the *Ignitor* module using the provided hardware in the same manner as a set of points. NOTE: 1281 kits use the points adjustment screw hole as a pilot for the *Ignitor* locating pin. Confirm the mounting plate is flat and fits without any drilling, cutting, or extra hardware. When the correct kit is installed modifications are not needed.
8. **If the distributor ground wire was removed during the installation process be sure it is re-attached securely.**
9. Place the magnet sleeve down onto the distributor shaft. Rotate the sleeve until you feel the cam line up correctly. Push down firmly until seated.
10. Set the air gap between the module and magnet sleeve using the provided plastic feeler gauge (0.030" thick). This is done in the same manner as points. Note: In some kits the modules are stationary and do not require air gapping.
11. Replace rotor and distributor cap. All spark plug wires should be seated securely.
12. Connect the *Ignitor* black wire to the negative (-) side of the ignition coil.
13. For installations that do not use a primary ballast resistor, connect the *Ignitor* red wire to the positive (+) side of the ignition coil. (See Figure 2).
14. For installations that use a primary ballast resistor, connect the *Ignitor* red wire to the ignition switch side of the resistor. (See Figure 3).
15. Reconnect battery and make sure all wires are connected.
16. The engine can now be started. Let the engine run for a few minutes and then set the timing in the conventional manner.

FIGURE 1  
WIRING DIAGRAM  
CONVENTIONAL POINTS  
SYSTEM  
WITH BALLAST RESISTOR

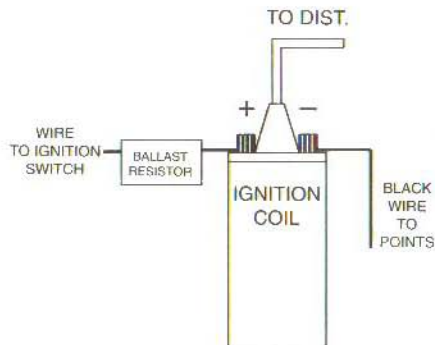

FIGURE 2  
WIRING DIAGRAM  
IGNITOR SYSTEM  
WITHOUT BALLAST RESISTOR

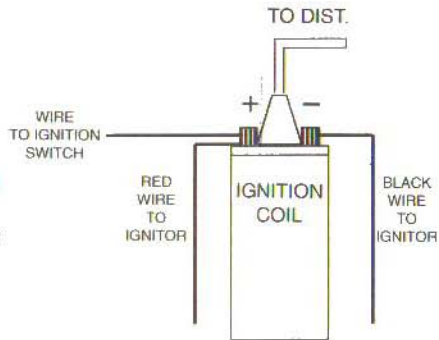
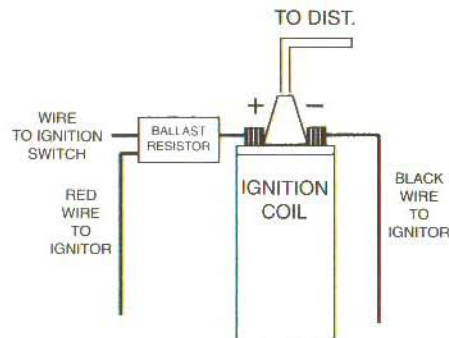

FIGURE 3  
WIRING DIAGRAM  
IGNITOR SYSTEM  
WITH BALLAST RESISTOR



NOTE: A RESISTOR WIRE OR BALLAST RESISTOR MAY OR MAY NOT BE INCLUDED IN THE ORIGINAL EQUIPMENT. THEY ARE NOT TO BE CHANGED IN ANY WAY WITH THE INSTALLATION OF AN IGNITOR SYSTEM.

## Ignitor™ COMMON QUESTIONS AND ANSWERS

**Q. What is the first thing I should check if the engine would not start?**

**A.** *Make certain all wires are connected securely to the proper terminals.*

**Q. The engine still will not start or runs rough. Are there any tests I can do?**

**A.** *Yes, remove the red Ignitor™ wire from the coil. Connect a jumper wire from the positive side of the battery to the red Ignitor™ wire just removed from the coil. If the engine starts you have a low voltage problem (This is a very common problem).*

*Remember this is just a test. Not intended for permanent installation.*

**Q. How can I fix a low voltage problem?**

**A.** *First, if you have an external ballast resistor, connect the red Ignitor™ wire to the ignition wire prior to the ballast resistor. Second, if you do not have a ballast resistor you must connect the red Ignitor™ wire to a 12-volt source that is controlled by the ignition switch.*

**Q. What type of a coil do I need?**

**A.** *The Ignitor™ is compatible only with a "points style" coil. Six & eight cylinder engines require a minimum of 1.5 ohms of resistance. Four cylinder engines require a minimum of 3.0 ohms of resistance.*

**Q. How do I check my coil for resistance?**

**A.** *First you need an ohmmeter. Remove all the wires from the coil. Attach the meter to both the positive and negative terminals. The reading must be 1.5 ohms or greater for six and eight cylinder engines, and 3.0 ohms or greater for four cylinder engines. (Your local auto parts store can do this for you if you do not have an ohmmeter)*

**Q. What do I do if my coil does not have enough resistance?**

**A.** *You may purchase and install a ballast resistor from your local auto parts store. You may also choose to purchase a Flame-Thrower™ 40,000-volt coil, which provides resistance internally. Note: Many vehicles come with a resistor wire or a ballast resistor. These applications do not need an additional resistor.*

**Q. What happens if I leave the ignition switch on when the engine is not running?**

**A.** *This can cause your coil to overheat, which may cause permanent damage to the coil and the Ignitor™.*

**Q. May I modify the length of the Ignitor™ wires?**

**A.** *Yes, you may cut the wires to any length your application may require. You may also add lengths of wire if needed (20-gauge wire). Please make sure all wire splices are clean and connections are secure.*

**Q. Will the shift interrupter on an OMC stern drive boat work with the Ignitor™?**

**A.** *The Ignitor™ is compatible with all OMC stern drive applications, when equipped with a "diode fix". If you have purchased a kit that did not include the "diode fix" diagram, call our tech line.*

**Q. How can I get additional help?**

**A.** *Call our tech line (800-827-3758) for further instructions or questions.*

# PERTRONIX<sup>INC</sup>



## Flame-Thrower™ LOW resistance... HIGH performance spark plug wires

Available in two versions.  
BOTH feature two current paths...

- 1) Spiral wound stainless steel alloy
- 2) Carbon impregnated fiberglass center core

BOTH include all these state-of-the-art features:

- Low 500 ohm per foot resistance
- Silicone jackets to resist high temperatures, moisture, oil and chemicals
- EPDM (Ethylene Propylene Diene Monomer) rubber inner insulation for superior heat resistance and prevention of arcing and voltage leaks
- Fiberglass reinforcing braid for added strength and flexibility
- Lifetime Warranty
- Made in U.S.A.



## More spark energy, with voltage to burn from the makers of The Ignitor.

While it's the perfect coil to go with the PerTronix Ignitor breakerless ignition, our new 40,000 volt Flame-Thrower can benefit virtually any distributor type induction system. For one thing, the higher voltage allows larger spark plug gaps for added power, smoother response and better fuel economy.

Choose from chrome or OEM black, they're oil filled for better cooling and voltage insulation; or get the epoxy version of the Flame-Thrower when extreme vibration is a factor.

## The 40,000 volt Flame-Thrower™ high performance coil. IT'S HOT!



Oil filled  
chrome or  
stock black.  
Epoxy  
version  
for racing.

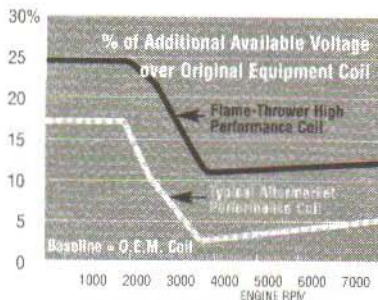

- Maximizes energy and reliability over the full RPM range
- 40,000 available volts
- Enables larger plug gaps for greater fuel efficiency, more power
- Delivers an average of 15% more spark energy and voltage
- Legal in all 50 states and Canada
- Fits existing brackets
- Made in U.S.A.



## LIMITED WARRANTY

Manufacturer warrants to the original Purchaser of its solid state ignition system (product) that the Ignitor, magnet assembly and wiring (components) shall be free from defects in material and workmanship for a period of (30) months from the first day of use in the Purchaser's industrial truck, stationary, auto or truck engine distributor.

If within the period of the foregoing warranty manufacturer finds after inspection that the product or any component thereof is defective, manufacturer will, at its option, repair such product or component or replace them with identical or similar parts PROVIDED that within such period Purchaser

1. Promptly notifies manufacturer in writing of such defect;
2. Delivers the defective product or component to manufacturer with proof of purchase date; and
3. Has installed and used the product in a normal and proper manner consistent with manufacturer printed instructions.

THE FOREGOING LIMITED WARRANTY IS EXCLUSIVE AND IN LIEU OF ALL OTHER WARRANTIES, WHETHER EXPRESS OR IMPLIED, INCLUDING ANY IMPLIED WARRANTY OR MERCHANTABILITY OR FITNESS FOR A PARTICULAR PURPOSE.

THE FURNISHING OF A REPAIR OR REPLACEMENT COMPONENT OR COMPONENTS SHALL CONSTITUTE THE SOLE REMEDY OF PURCHASER AND THE SOLE LIABILITY OF MANUFACTURER. WHETHER ON WARRANTY, CONTRACT OR FOR NEGLIGENCE, AND IN NO EVENT WILL MANUFACTURER BE LIABLE FOR MONEY DAMAGES WHETHER DIRECT OR CONSEQUENTIAL.